



Serta® Grid Full RTA Frame and Hinge

www.sertafutons.com

Monday through Friday (Except Holidays)
9 a.m. to 5 p.m. Eastern Time

Thank you

for selecting a Serta® Futon. We've taken great care in the design and hand crafting of each piece so that assembling your futon is enjoyable and rewarding. By carefully following the simple assembly instructions, you will have created a piece of furniture that will provide years of enjoyment.

Care and Maintenance

The care required for your new futon arm and frame is no different from any other piece of fine furniture in your home. A soft damp cloth will easily clean your furniture. Avoid excessive moisture (especially from condensation forming on cold drinks) and open flame or hot candle wax. As with all fine furniture, exposure to direct sunlight, over time, will lighten the finish.

Before You Begin Assembly

Before you begin, select a suitable area for assembly of the unit ... preferably an open space on soft carpet. If assembling on hard floor, we recommend laying down a blanket so that you will not scratch or mark either furniture or floor .

We take great care to make sure each piece comes with everything you'll need. If you find a part missing, or have questions, just call us at www.sertafutons.com.

Hardware List

Item	Description	Qty
A	Left Hinge	1
B	Right Hinge	1
C	Seat Section	2
D	Back Section	2
E	Stretcher Rail Section	4
F	Short Hex Socket Head	36
G	Long Hex Socket Head	16
H	Flat Washers	24
I	Nut	8
J	Allen Wrench	1
K	Open End Wrench	1
L	Hook	2
M	Rubber Pads	4
N	Lock Washer	28
O	Seat Back/Bottom Connector tubes	4
P	T Leg	2
Q	Stretcher Rail Insert Connector	2

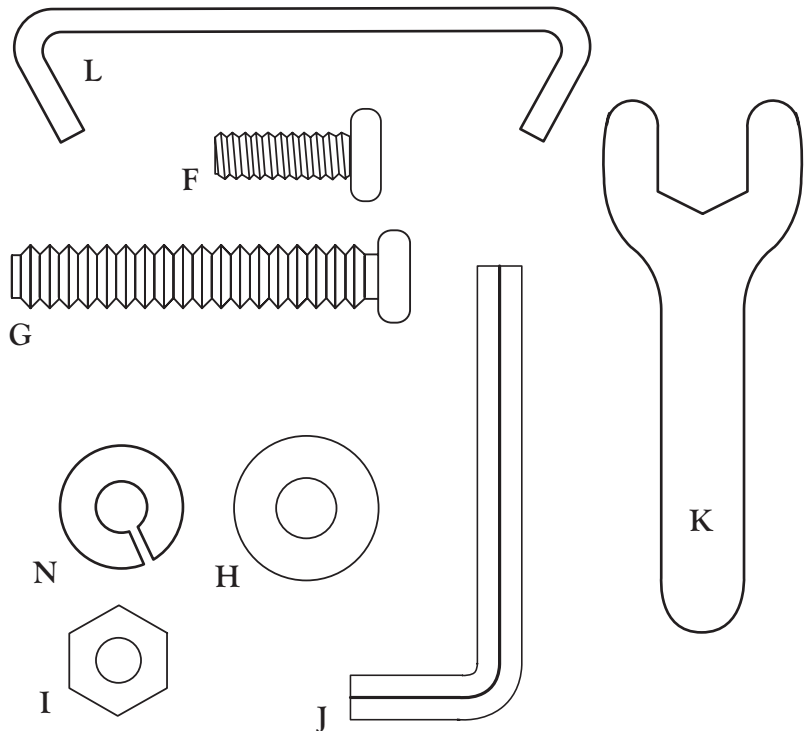

Serta Futon Customer Service
www.sertafutons.com

Rev. 3/2007

HOW TO ASSEMBLE LEFT HINGE AND LEFT ARM

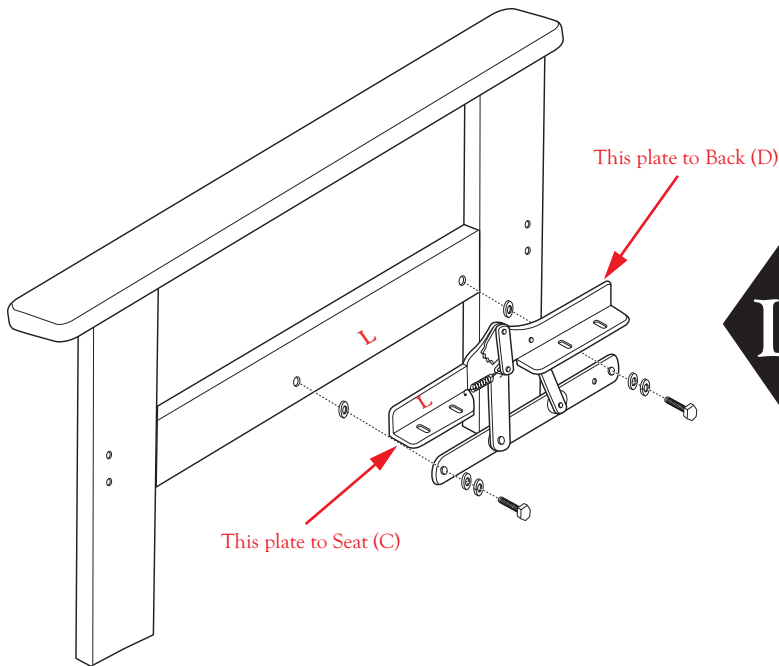

Before assembling LEFT ARM to LEFT HINGE, please ensure you've done the following:

- Open the 2 hinges inside your hardware kit. You will find an "L" printed on one of the hinges. This is the LEFT hinge. Please see sketch.
- Open the 2 arms packaged with your futon. You will find an "L" sticker on one of your arms. This is the LEFT arm. Please see sketch.

After you have identified the LEFT hinge and the LEFT arm, attach the hinge to the arm as detailed.

IMPORTANT: FAILURE TO ATTACH THE CORRECT ARM TO THE CORRECT HINGE WILL CAUSE THE FUTON TO OPERATE INCORRECTLY.

HOW TO ASSEMBLE RIGHT HINGE AND RIGHT ARM

Before assembling RIGHT ARM to RIGHT HINGE, please ensure you've done the following:

- Open the 2 hinges inside your hardware kit. You will find an "R" printed on one of the hinges. This is the RIGHT hinge. Please see sketch.
- Open the 2 arms packaged with your futon. You will find an "R" sticker on one of your arms. This is the RIGHT arm. Please see sketch.

After you have identified the RIGHT hinge and the RIGHT arm, attach the hinge to the arm as detailed.

IMPORTANT: FAILURE TO ATTACH THE CORRECT ARM TO THE CORRECT HINGE WILL CAUSE THE FUTON TO OPERATE INCORRECTLY.

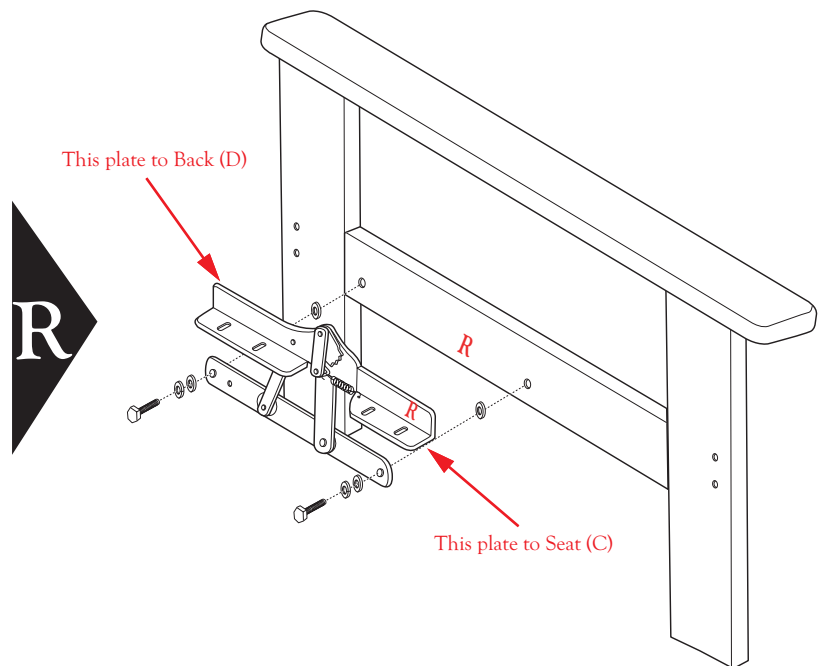

Serta® Grid Full RTA Frame and Hinge

Install the Hinges to the Arms

Bolt the left hinge (A) and right hinge (B) to the arms using the 4 short hex socket head bolts (F) and 8 flat washers (H) and 4 lock washers (N) as shown.

Make sure hinge is positioned as shown.

(If the hinges are tight when opening and closing you can use a little oil on the pivot points.)

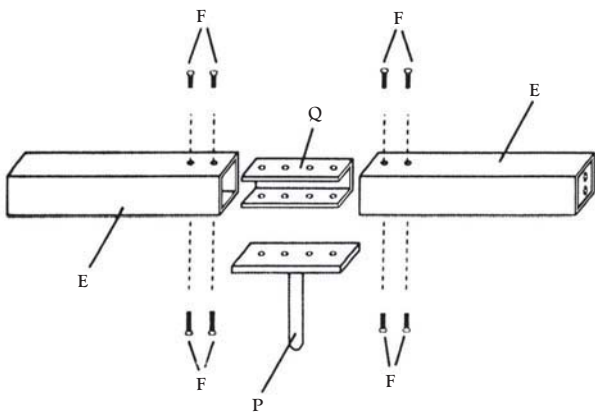
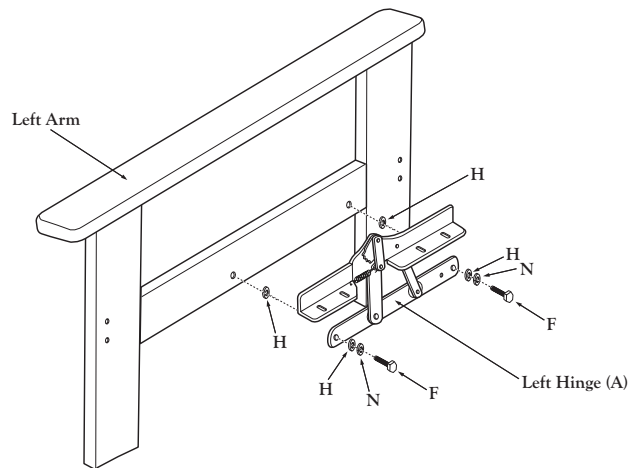

Assemble Stretcher Rails

Using the 4 short hex socket head bolts (F) assemble the stretchers rails (E). Begin by inserting the insert connector (Q) into each section. Insert 4 bolts through the top and hand tighten. Align the T Leg (P) with the bottom holes, insert 4 bolts and hand tighten. Tighten all 8 bolts. Repeat to assemble the 2nd stretcher rail.

Attach Arms to Stretcher Rails

Using the 8 long hex socket head bolts (G) attach the two rails to the arms. **Important:** Before you tighten the individual bolts make sure you start all 8 bolts first. Install pads (M) between rails and the frame to prevent scratches .

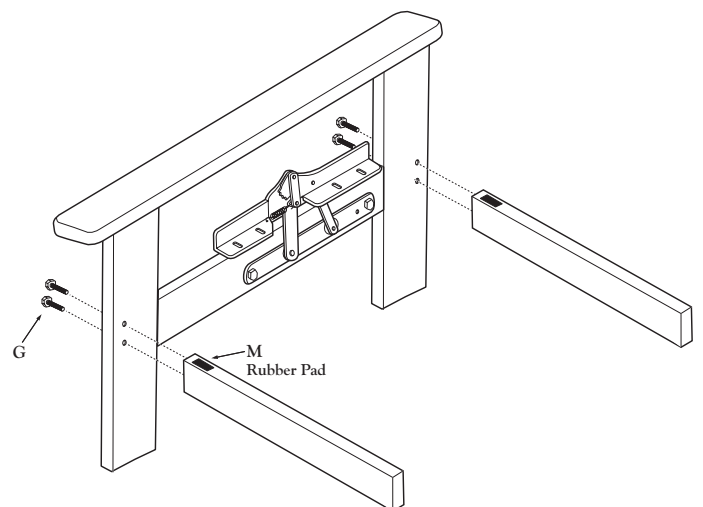

Serta® Grid Full RTA Frame and Hinge

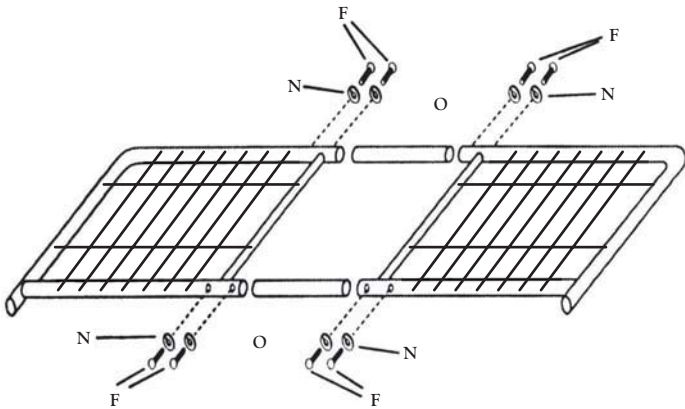

4

Assemble Seat/Back Frames

Assemble the seat back (D) using Short Hex Socket Head bolts (F), 8 lock washers (N) and 2 connector tubes (O). Insert the two connector tube into one section of the back frame. Secure with 4 bolts and hand tighten. Now insert the 2nd back frame section into the connector tubes. Secure with 4 bolts and hand tighten. Once all 8 are correctly inserted tighten securely. Repeat this procedure for the seat bottom.

Attach Seat

Attach the seat bottom (C) to the front portion of the hinge using 4 Long Hex Socket Head bolts (G), 8 flat washers (H), 4 lock washers (N) and 4 Nuts (I). **NOTE:** For full size frames make sure that the “U” shaped metal that is pre-attached to the seat is pointing up. This helps to hold the futon mattress in place.

5

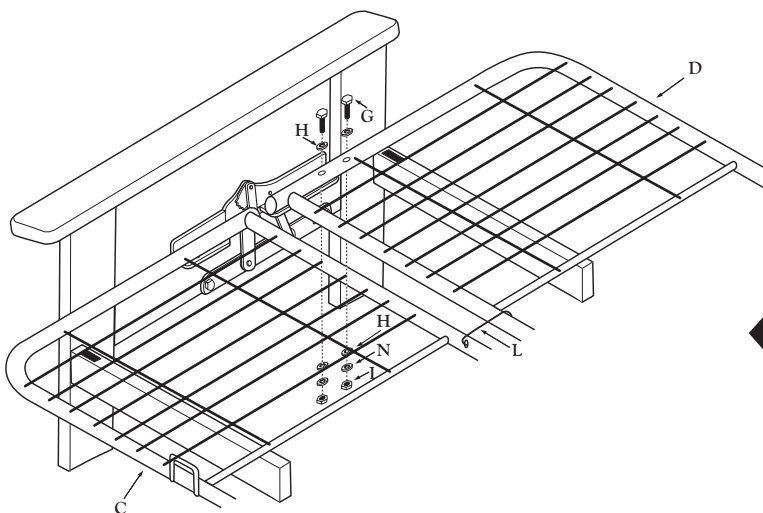
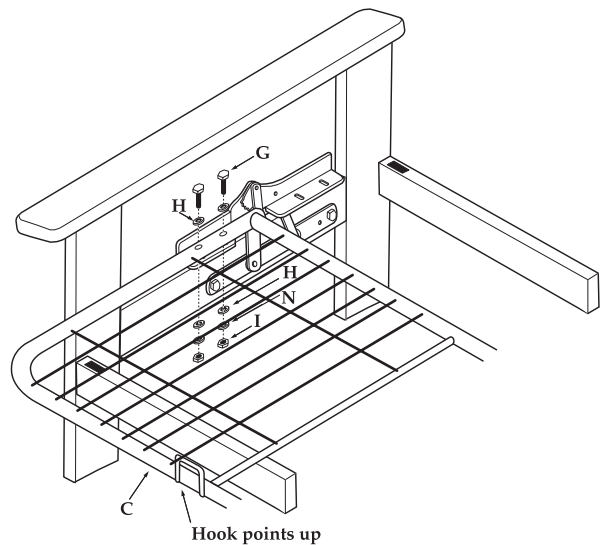

6

Attach Back

Attach the seat back (D) to the back portion of the hinge using 4 Long Hex Socket Head bolts (G), 8 flat washers (H), 4 lock washers (N) and 4 Nuts (I). For extra strength, attach the two hooks (L) between the seat and back in the pre-punched holes. **Insert Futon Mattress and take a Nap!**

Serta® Grid Full RTA Frame and Hinge

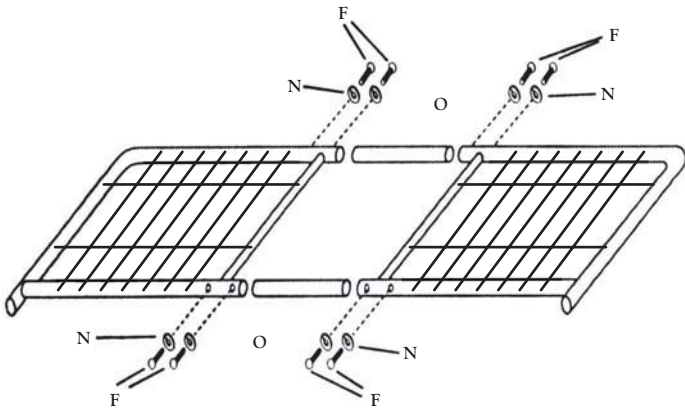

4

Assemble Seat/Back Frames

Assemble the seat back (D) using Short Hex Socket Head bolts (F), 8 lock washers (N) and 2 connector tubes (O). Insert the two connector tube into one section of the back frame. Secure with 4 bolts and hand tighten. Now insert the 2nd back frame section into the connector tubes. Secure with 4 bolts and hand tighten. Once all 8 are correctly inserted tighten securely. Repeat this procedure for the seat bottom.

Attach Seat

Attach the seat bottom (C) to the front portion of the hinge using 4 Long Hex Socket Head bolts (G), 8 flat washers (H), 4 lock washers (N) and 4 Nuts (I). **NOTE:** For full size frames make sure that the “U” shaped metal that is pre-attached to the seat is pointing up. This helps to hold the futon mattress in place.

5

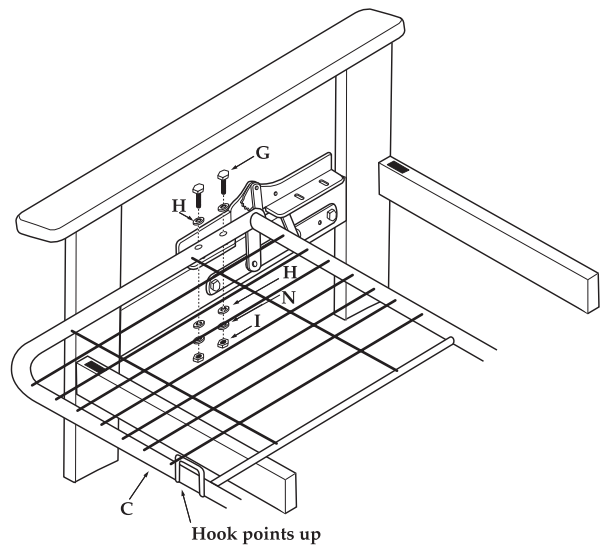

Attach Back

Attach the seat back (D) to the back portion of the hinge using 4 Long Hex Socket Head bolts (G), 8 flat washers (H), 4 lock washers (N) and 4 Nuts (I). For extra strength, attach the two hooks (L) between the seat and back in the pre-punched holes. **Insert Futon Mattress and take a Nap!**

6

